

1. Pressure air section 1913

Pneumatic setting



The setting at both pressure reducer should be approx. 3 bar

Edge course setting

If the edge course with 0.4mm melamin edge not straight or the edge course move up or down it is possible to adjust the course with the pressure air section.

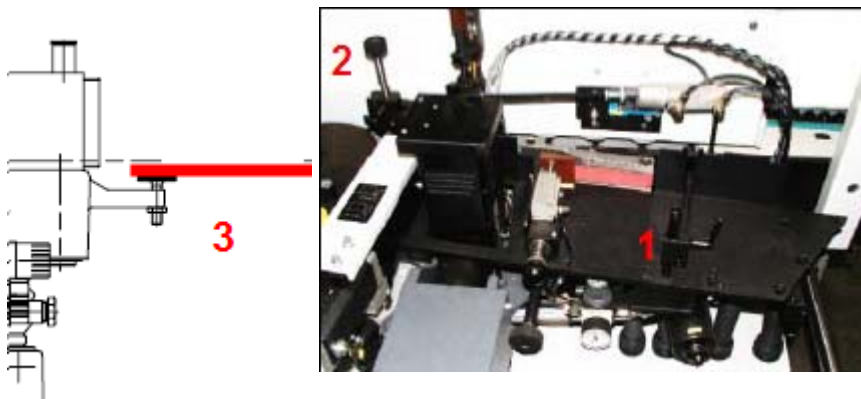

First move the lower press pad 1 + 2 cpl. Up.
Adjust the support screw 3 in a position where the edge feeding plate touch the screw without tension.

Use a workpiece min. 1,5m long up-glued with 0,4 melamin edge and without cutter processing.

If the edge at the end from the workpiece moving up or down you have to adjust the pressure air section as follow.

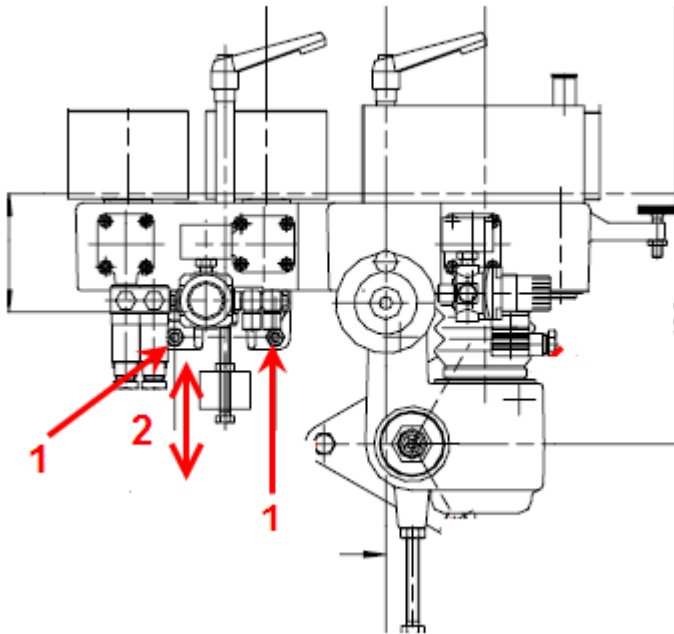

Loosen the screws 1 and move the position 2 up or down.

Edge course at the end up → position 2 should be down.

Edge course at the end down → position 2 should be up.